



North America UBC Product Quality Specification

Rev 5
January 2018

Document Manager: Kerry Ward
Approved by: Michael Anderson

Note: This is considered an uncontrolled document unless it is being viewed on-line from the SharePoint or from a printed copy at one of the following controlled locations:

NONE

TITLE: UBC Product Quality Specification

1.0 PURPOSE:

Novelis is a supplier to discerning customers of a wide variety of rolled aluminum products. Novelis' viability in these markets depends on its' ability to consistently supply aluminum of the highest quality. A major factor in our ability to meet this requirement is the quality of the raw material we purchase for our processes with UBC representing a meaningful percentage of our raw material mix.

It is for this reason that we have developed this manual, the major purpose being to communicate as clearly as possible, the Novelis requirements for high quality UBC. The philosophy of Novelis is to work with all of its suppliers to enable them to continuously improve the quality of materials delivered.

2.0 GENERAL QUALITY STATEMENTS:

- a) All UBC Shipments, both domestic and international, shall fully comply with the Novelis Product Quality Specification as written in this document.
- b) Used beverage cans ("UBC's") purchased by Novelis for use at its facilities are expected to be free of any potential safety, hygiene or environmental hazards ("contaminants"). Prior to supplying UBC's to Novelis, each supplier location will work with his/her Novelis Buyer to become "qualified" through the demonstration of ability to meet the outlined quality requirements. Refer to the **Novelis New Supplier Qualification Procedure** for requirements and guidelines. This UBC Product Quality Specification is intended to provide guidance as to the quality expectations for suppliers of UBC to Novelis.
- c) Each load of UBC's received at a Novelis site will be inspected for adherence to this specification and assigned an overall quality rating. These ratings will be tracked by supplier location and reports will be generated periodically that measure that location's ability to meet the Novelis UBC Specification. These quality ratings will be used to evaluate the quality level of the UBC's that are being supplied by each supplier's location.
- d) All UBC material must be magnetically separated prior to shipment to Novelis facilities.
- e) Material that does not meet the requirements of this Product Quality Specification may generate a DMR ("Defective Material Report") and be subject to rejection. To remain a fully qualified supplier, it is expected that the supplier will document the corrective actions taken to eliminate the cause(s) of their failure to fully satisfy the specification. For more detail, please refer to the **Novelis Defective Material Report Procedure**.

TITLE: UBC Product Quality Specification

3.0 PRODUCT QUALITY REQUIREMENTS:

3.1 Safety Issues

The presence of the following items in a load of UBC are hazardous to the customers of Novelis and as such are cause for immediate rejection and potential disqualification due to the threat they pose to employees.

- a) Medical waste/hypodermic needles
- b) Pressurized aerosol cans with or without liquid
- c) Live ammunition/explosives
- d) Butane lighters
- e) Fertilizers/oxidizers
- f) Containers of liquid
- g) Propane/gasoline containers
- h) Free lead
- i) Radioactive sources
- j) Unidentifiable materials/substance
- k) Infestation of the UBC by insects, rodents, etc.
- l) Batteries (lead cell)

3.2 Contaminants

The presence of the following items in a load of UBC material may deem reason for rejection.

- a) Paper
- b) Iron & Steel, brass, bronze and other nonferrous metals
- c) Batteries
- d) Rocks, dirt, sand and glass
- e) Rubber, foil, pie pans, and wood
- f) Insulated beverage containers
- g) Excessive Moisture – Please note that loads with a moisture level greater than 4% of the load weight will be subject to a weight deduction (financial penalty) or rejection. See section 3.5 for detail.
- h) Plastic – This includes both free plastic and/or plastic added to UBC during the manufacturing process such as plastic label sleeves, plastic in bottle caps, plastic screw tops, nitrous widget balls, plastic nitrous tops, etc.

TITLE: UBC Product Quality Specification

- a. Below are some examples of plastic attached to UBC during the manufacturing process:



Plastic Wrap Label



Plastic Screw Top



Plastic Top



Plastic Nitrous Top

3.3 Other Aluminum Cans

Aluminum food cans (including pet food cans) are acceptable interspersed with UBC's, but must not make up more than 10% of each bale or bundle by volume. These cans must be clean, dry and free of the paper label.

TITLE: UBC Product Quality Specification

3.4 Loads Infested with Insects

- a) Fumigation may be required to aid in the control of infestation to protect the health and safety of employees and processes. When fumigation is necessary, Novelis requires the use of two 6 oz. canisters of PCO Fogger-Total Release with Pyrethrins manufactured by Waterbury Company or equivalent brand. One should be placed as close to the front and the other as close to the rear of the load to control the flying insects and/or maggots. We request that the cans are removed and not shipped in the container. For control of other infestations, see your market contact regarding current appropriate products approved for use.
- b) On occasion and during the warmer summer months, flying insects or fruit flies become a problem in certain areas. If this happens and your area is identified as a high risk area, you will be contacted to begin a fumigation program until the issue is resolved.

3.5 Moisture

UBC should be dry; therefore, it is suggested that material not be stored or processed outside. A random sample will be pulled from each load to calculate a moisture percentage. Shipments with moisture in excess of 4% will be subject to a weight deduction or rejection. The deduction will equal the tested moisture percent minus 2%. See example below.

Received Weight	Tested Moisture %	Moisture Allowance Deduction %	% Deduction	Weight Deduction (lbs)
40,000	4.5	2	2.5	1000
40,000	4.1	2	2.1	840
40,000	4	No Deduction		0
40,000	3.5	No Deduction		0

4.0 UBC DOMESTIC & INTERNATIONAL SHIPPING & PACKAGING REQUIREMENTS:

Non-conformance to the Packaging and Shipping Requirements for UBC material will be subject to rejection. Freight charges and all other charges incurred by the rejected scrap will be paid by the supplier ship location.

UBC material must be baled or densified. Novelis requires UBC to be free from packaging such as; shrink-wrapping, fiber cartons, fiber or metal drums, pallets, and metal or wooden boxes. Loads with any of these types of packaging materials will be subject to rejection and/or weight deduction. Loads identified with dunnage will have an equal deduction in scaled weight.

5.0 UBC PACKGED IN BALES:

- a) Bales of UBC (see figure 1) must be a least 30 cubic feet with dimensions in inches in the following ranges: 24" to 41" x 30" to 52" x 41" to 72".

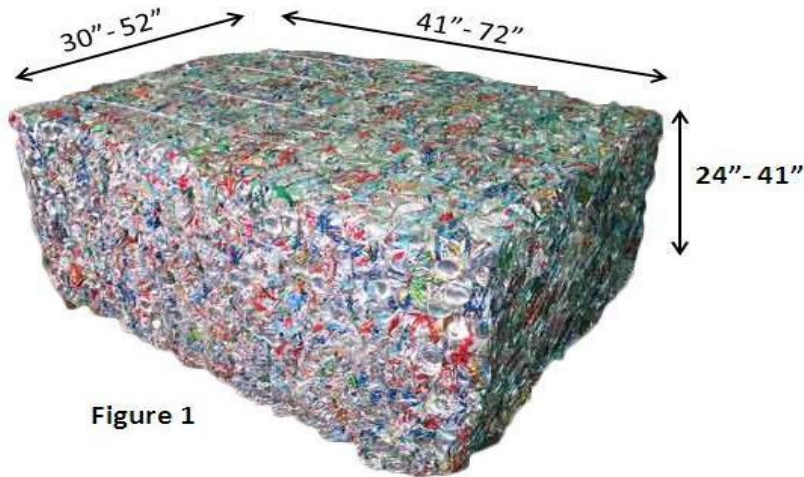

Figure 1

- b) Acceptable bale densities are 14 to 25 lbs. per cubic foot. All bales must be dense enough to allow safe handling and storage (stacking) by forklift.
- c) The bale package must be safe and secure to be unloaded and stored.
- d) Bales require a maximum of six 5/8" x .02" steel bands or a maximum of six #13 gauge steel wires is required. Insufficient, additional or embedded banding is not acceptable and will be subject to rejection.
- i. Excessive wire beyond the binding twist (pig tails) or banding beyond the clamp or crimp is not acceptable as they create potential safety hazards when being removed by hand.
 - ii. Banding should be sufficiently tightened to secure the material but not so tight as to be embedded or produce a springing action when cut.

5.1 UBC Packaged In "Biscuits" – Densified:

- a) Biscuit bundles of UBC (see figure 2) must be of uniform size. Acceptable bundle range dimensions in inches are 40" to 44" x 51" to 54" x 54" to 65". All bundles must allow safe handling and storage by forklift.
- b) Acceptable biscuit density is 35 to 50 lbs. per cubic foot. Dimensions per biscuit should be no greater than 10" to 13" x 10.25" to 20" x 6.25" to 9". A biscuit shall not exceed 50 lbs. in weight.
- c) Bundles are to be banded with minimum 5/8" x .02" thick steel straps. One vertical band per column required and a minimum of two horizontal bands per bundle.

TITLE: UBC Product Quality Specification

d) Density Calculation:

Length (in inches) x Height (in inches) x width (in inches) / 1,728 = Total Cubic Feet. Weight of Bale or Biscuit (in pounds) / Total Cubic Feet = Density in Pounds per Cubic Foot.

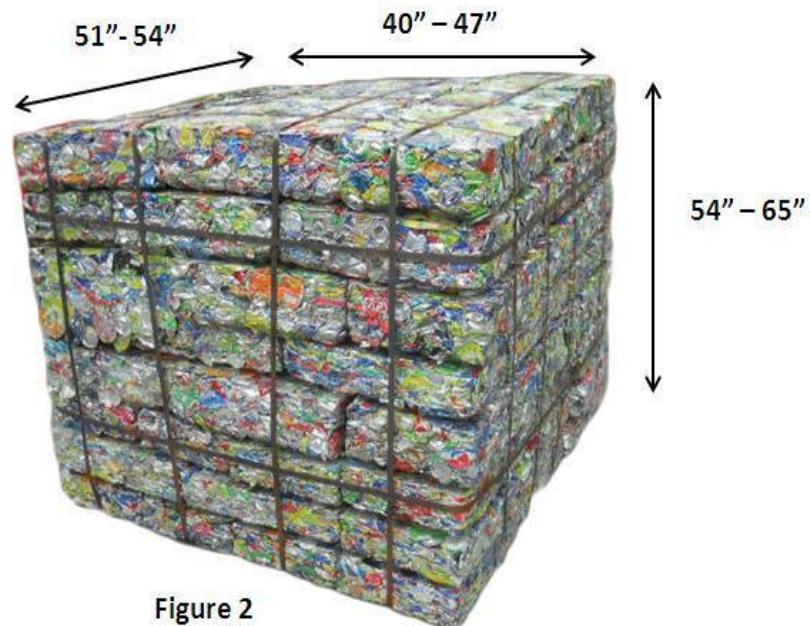

Figure 2

6.0 UBC LOADING & SHIPPING BY TRUCK:

- a) All UBC must be loaded in standard dry vans with swing out barn doors, and sliding tandem axles only.
- b) Novelis' transportation partners will provide either 48' or 53' trailers for loading.
- c) Suppliers are responsible for checking all trailers prior to shipment. Trailers shall be in good shape, dry and free of holes or weakened floors. Trailers must be suitable for safe entry and exit of mobile equipment (i.e. forklifts). Employees have the right to reject the load if deemed unsafe for forklift entry.
- d) Loads shipped by van trailer require a minimum of six inches between the top of the load and the lowest point of the trailer roof, and at least four inches of side clearance on each wall to allow removal by forklift.
- e) Bracing bars or other bracing components should be loaded at the end of the trailer to prevent metal from shifting in transit.
- f) Bales must be loaded in van trailers with the largest face on the floor perpendicular to the sides of the trailer (see Figure 3). If length prevents

TITLE: UBC Product Quality Specification

- side by side loading of the bales, load with the longest side parallel to the side of the trailer or a combination of perpendicular and parallel to maximize utilization of the inside dimensions of the trailer (see Figure 4). Bales loaded on end are not acceptable. Baled UBC should be loaded to prevent any shifting while in transit.
- g) Densified bundles should not be double stacked and should be braced where necessary to prevent shifting in transit.
 - h) Truck weights for bales should be a minimum of 38,000 lbs., and truck weights for biscuits are a minimum of 40,000 lbs. If the weights do not meet this requirement (FOB shipping point terms only), the shipper will be subject to the **Novelis Deficient Weight Policy**.
 - i) In the case of intermodal shipments originating in CA, OR, WA, NV, ID, UT, WY, AZ, BC, AB, SK or MB the maximum load weight cannot exceed 43,500 lbs. Loading greater than 43,500 lbs. may result in a situation where the truck could be overloaded at some point in the route and result in fines or a dangerous situation. Loads will need to be secured by the shipper in accordance with railroad securement regulations and as provided by the carrier. When shipping intermodal, a copy of the shipper bill of lading or packing list must be affixed to the inside rear trailer wall (not the doors). A documentation research fee will be assessed for loads arriving without the required paperwork.
 - j) Novelis **requires** drivers to scale their equipment after loading. On occasion, drivers may return to the loading facility to have some or part of their load re-distributed so as to be able to scale legally on the highway. In all cases, the driver is the deciding voice in ensuring the metal is loaded securely and can be transported safely.

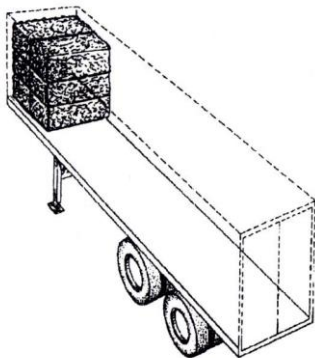

Figure 3

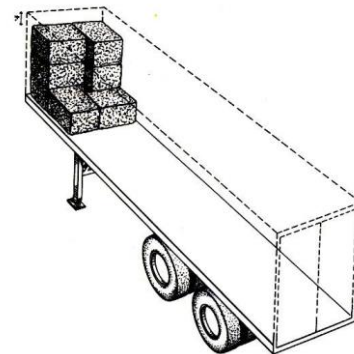

Figure 4

TITLE: UBC Product Quality Specification

7.0 UBC LOADING & SHIPPING BY RAIL:

- a) All UBC must be loaded in railcars with solid interior walls. Railcars must be clean and free of foreign material.
- b) All railcars must be in good condition and free of holes in the floor.
- c) All railcars should have doors with a minimum width of 10 feet, with a minimum height of 9 feet 6 inches.
- d) Railcar weights for bales / biscuits are a minimum of 83,000 lbs. (bales) and a minimum of 110,000 lbs. (biscuits). If the weights do not meet this requirement (FOB shipping point terms only), the shipper will be subject to the Novelis Deficient Weight Policy.
- e) Load bales in ends of railcar with longest dimensions perpendicular to railcar sides (see Figure 5). Bales or bundles should rest on their largest face, and not on their ends.
- f) Load doorway bales with longest dimension parallel to railcar sides.
- g) All voids must be filled with fixed bracing to prevent the load from shifting during transit.
- h) Railcars must be accessible from either side, and securement must be in place to prevent metal from shifting against the door in transit.

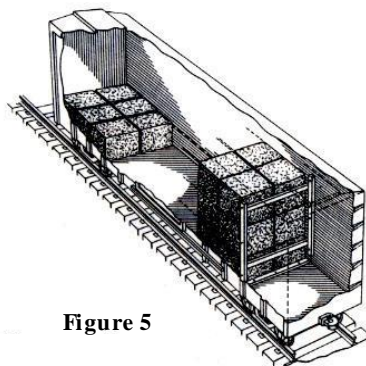

Figure 5

8.0 INTERNATIONAL UBC LOADING & SHIPPING IN CONTAINERS:

- a) On shipments made in ocean containers, the maximum weight that can be loaded into a container is 20 metric tonnes (40-foot containers) or 18.4 metric tonnes (20-foot containers). Loading a container over its maximum weight will incur additional freight and handling charges for the supplier unless arrangements have been made with and approved by Novelis prior to shipping.

TITLE: UBC Product Quality Specification

- b) All UBC’s loaded in containers require a minimum of six inches (15.25 cm) between the top of the load and the lowest point at the container door, and at least four inches (10 cm) of side clearance on each wall to allow removal by forklift. If densified bundles, the fork truck pockets must be accessible from the rear of the container.
- c) All containers must have a minimum clearance at the door of 8 feet 5 inches (101 cm) in order for Novelis fork trucks to be able to offload UBC. Containers with a smaller opening than 8 feet 5 inches will be rejected.
- d) All densified bundles must be banded with minimum 5/8” x .02” thick steel straps to prevent the load from shifting in transit. One vertical band per column and a minimum of two horizontal bands per bundle are required.
- e) Any blocking and bracing must be done at the rear of the load to facilitate removal at the destination. All wood used in bracing must be chemically treated in accordance to US import regulations.
- f) All international UBC loads are to be fumigated prior to shipping unless a written waiver is obtained from the Novelis Quality Specialist prior to shipping the first load. See section 3.4 for details.

9.0 STRAPPING/BANDING DEDUCTION:

Wire and banding weight will automatically be deducted from the received weights based on piece count. A 2.5 pound per bale deduction will be taken for banding, and a 7 pound per bundle deduction will be taken for densified.

Strapping/Banding Weight Deduction Example:

Number of bales Received	Banding Deduction per bale (lbs)	Total Weight Reduction (lbs)	Scaled Weight at Novelis Plant Site	Supplier Paid Weight
42	2.5	105	42,000	41,895
Number of bundles Received	Banding Deduction per bundle (lbs)	Total Weight Reduction (lbs)	Scaled Weight at Novelis Plant Site	Supplier Paid Weight
20	7	140	40,000	39,860

TITLE: UBC Product Quality Specification

10.0 SHIPPING DOCUMENTATION:

The driver must provide the following core shipment information must appear on the Bill of Lading and is required for all shipments of UBC;

- a) SRA number (Shipping Request Authorization) or purchase order number
- b) Shipper name, city, and state
- c) Type of product: UBC (baled or densified)
- d) Piece count
- e) Indicate actual scale weight or an estimated weight, which must be marked "estimated"
- f) Ship date
- g) Certification: "This shipment is being transported for the purpose of recycling as defined in the applicable tariffs containing such provisions."
- h) Duplicate bill of lading is required at the receiving location

11.0 RECORDS:

- a) Novelis New Supplier Qualification Procedure
- b) Novelis Defective Material Report Procedure
- c) Novelis Deficient Weight Policy

12.0 CHANGE CONTROL:

The requirements of this procedure are in effect until it is revised by Novelis.